

STUDER

PROFESSIONAL AUDIO EQUIPMENT

Service Information

STUDER D820 MCH
Modifications
and
Software Update V2.2

SI 154/91 Order No. 10.85.7300 (Ed. 0791)

Prepared and edited by:
STUDER International
a division of STUDER REVOX AG
Technical Documentation
Althardstrasse 10
CH-8105 Regensdorf-Zürich

D820 MCH - MODIFICATIONS AND S/W UPDATE V2.2

Contents:

1. Modifications: S/W 2.2
2. Modifications: Hardware
3. Improvements in S/W 2.2
4. Software Compatibility List
5. Status Control Sheet
6. Mechanical Modifications and Improvements
7. Confirmation Sheet

ATTENTION:

Please return

- Confirmation sheet
- all old EPROMS/EEPROMS/GALS

after performing the update

1. Modifications: S/W 2.2**SUPPOSITION:****MACHINE HAS TO BE MODIFIED TO S/W 2.1 (07/91)**Modification concerns:

- 1.862.655.21 CPU with
- 1.862.686.21 CPU Piggy Back
- 1.862.656.21 Peripheral Interface (PIF)
- 1.862.657.23 Reference Time Board (RT)
- 1.862.665.20 Sound Memory (SMEM)
- 1.862.781.21 MP-Unit TD Control PCM MCH
- 1.862.815.21 Display Panel μ P-Board
- 1.328.631.20 PAI Rembus μ P 6803

Modification set contains:

- CPU Master software (Set of 4) 1.862.926.22
- PIF Main Program 1.862.938.22
- PIF "SBC_TIM" 1.862.932.21
- RT TMS Main Program H 1.862.958.24
- RT TMS Main Program L 1.862.959.24
- TD PCM MCH (Set of 2) 1.862.797.22
- DP Part one 1.862.825.22
- DP Part two 1.862.826.22
- SMEM 56000 Program H 1.862.890.21
- SMEM 56000 Program M 1.862.891.21
- SMEM 56000 Program L 1.862.892.21
- PAI Main Program 1.328.896.21
(only on request)

ATTENTION!!

Before performing the master software update, please make sure, that all machine parameters are filed to disk or that you have your factory machine parameter disk available.

Use the program `nv_para.exe`, which came with the machine, to download the parameters when the update is performed.

Modification CPU Piggy Back 1.862.686.21

Problem:

New Master software V2.2 (28/91).

Remedy:

- Replace IC3 - 6 (old software number 1.862.926.21) by new software 1.862.926.22.

Change board index to new 1.862.686.22 .

Change also board index of CPU Force to new 1.862.655.22 .

```

*****
*
* ATTENTION:
* Machine parameters lost after Master Software Update.
* Remember backup !
*
*****

```

Concerns machines delivered before July 1991.

1.862.926.22

(SET OF 4 IC)

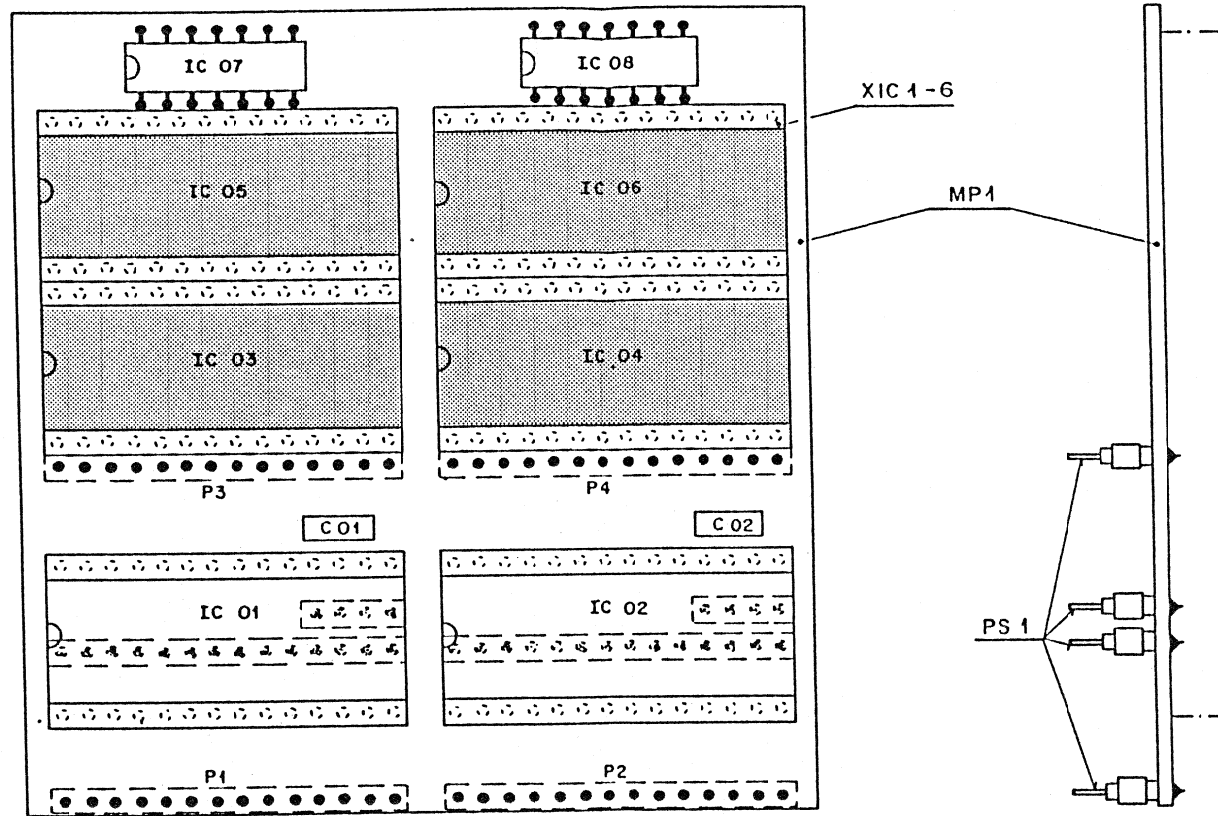

Schilder 1.862.686-01 / 43.01.0108 / 1.101.001-20
aufgeklebt nach Fabrikationsmuster.

Werkstoff	Norm-Nr.:	Güte:		Änderung					③	
	DIN-Bez.:	Beh.:								②
	Abmessung:									①
Zugehörige Unterlagen:		Freimasstoleranz:	Maßstab:	Datum	Gez.	Gepr.	Ges.	Index	④	
PL		±	2:1							19.5.89
Ersatz für:		Ersetzt durch:		Kopie Nr.:						
STUDER REGENSDORF ZÜRICH		Benennung: CPU-PIGGI-BACK ESE		Nummer: 1.862.686-22						

<u>Modification</u>	<u>Peripheral IF</u>	<u>1.862.656.21</u>
---------------------	----------------------	---------------------

Problem:

- Faulty SERBUS-transmission under several circumstances due to timing problems with new components specifications.
- Implementation of new Master software V2.2 (28/91).

Remedy:

- Replace IC33 (old software number 1.862.932.20) by new software 1.862.932.21.
- Replace IC43 (old software number 1.862.938.21) by new software 1.862.938.22..
- Cut three conducting paths (marked "A", "B" and "C") as indicated on wiring plot.
- Add a wire from IC19, pin 8 to IC55, pin 19.
- Add a wire from IC48, pin 3 to IC19, pin 3.
- Add a wire from IC33, pin 16 to IC25, pin 1.

Change board index to new 1.862.656.22 .

Concerns machines delivered before July 1991.

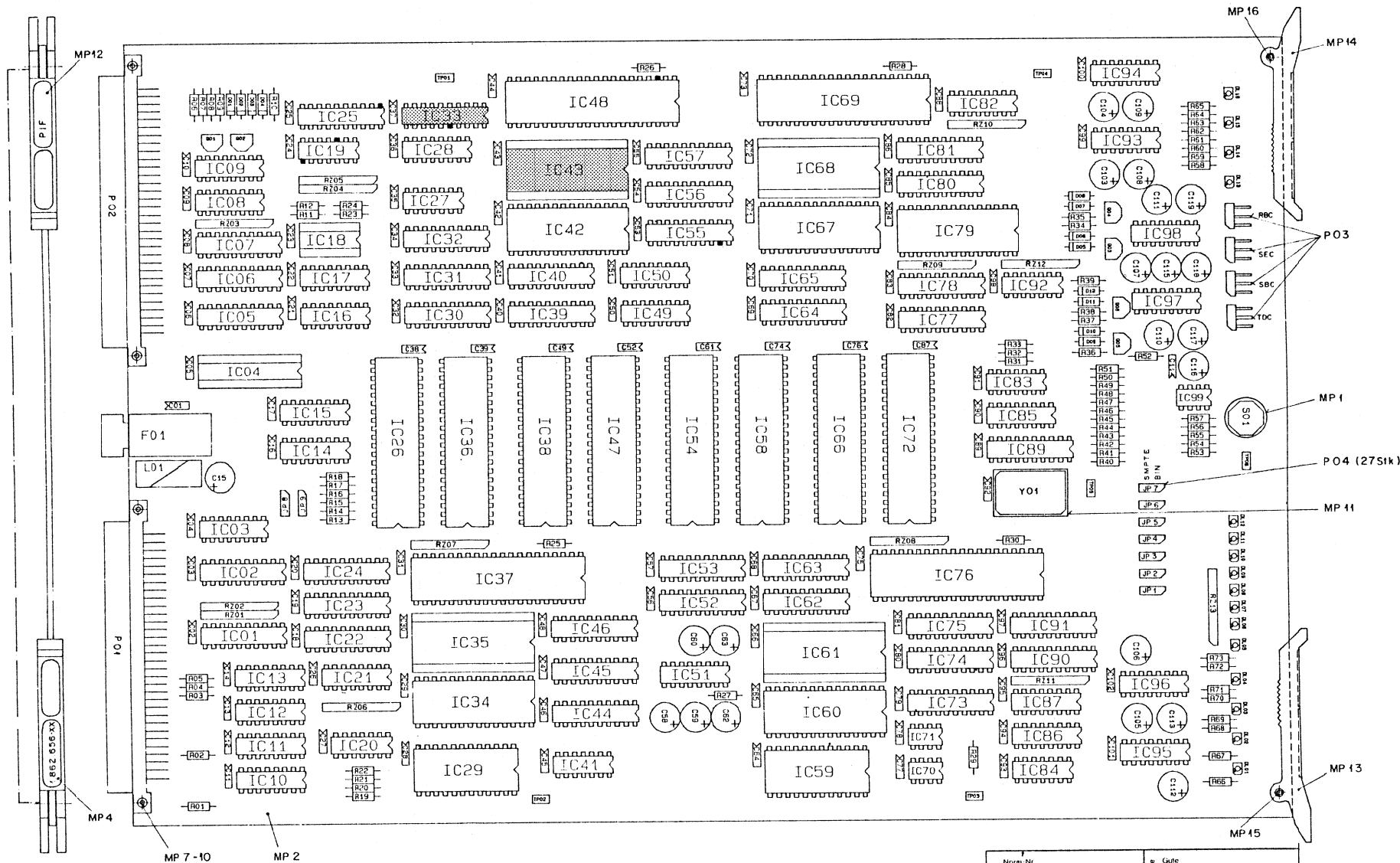

Norm-Nr		Güte	
DIN Bez		Oberfläche	
Abmessung		Boh	
Zugehörige Unterlagen		Freiwilligkeit	Maßstab
PL, BV 640			1,3:1
Ersatz für		Ersatz durch	Kopie für
STUDER REGENSDORF ZÜRICH		PERIPHERAL INTERFACE ESE	
Bezeichnung		Bezeichnung	
1.862.656-22		1.862.656-22	

6'9.89 *A 10.15.69*
 Datum Grz Gmz Ges Index
 Kopie für

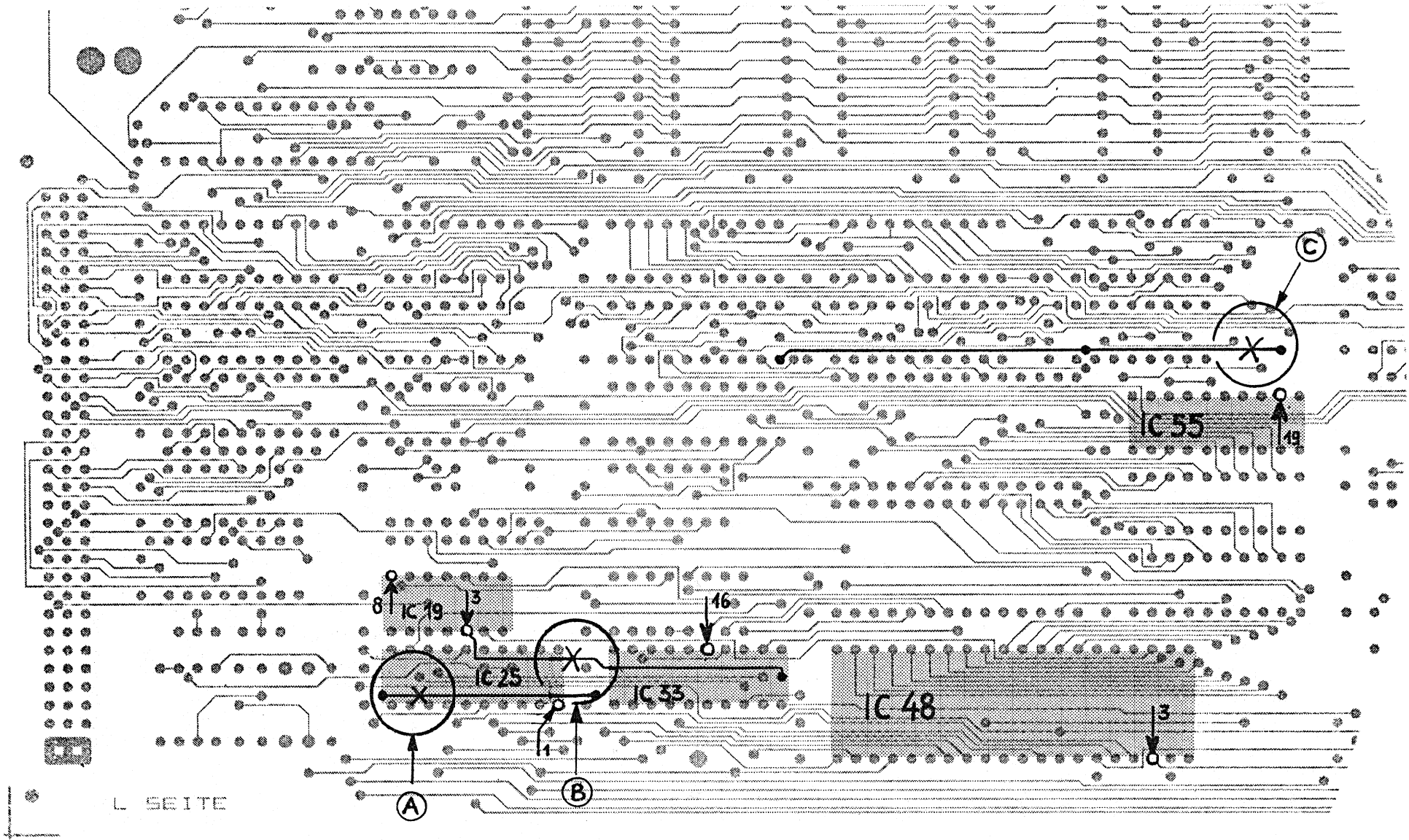

L SEITE

MODIFICATION PIF-BOARD 1.862.656.22

Modification Reference Track Board 1.862.657.23

Problem:

New Master software V2.2 (28/91).

Remedy:

- Replace IC48 (old software number 1.862.958.23) by new software 1.862.958.24.
- Replace IC67 (old software number 1.862.959.23) by new software 1.862.959.24.

Change board index to new 1.862.657.24 .

Concerns machines delivered before July 1991.

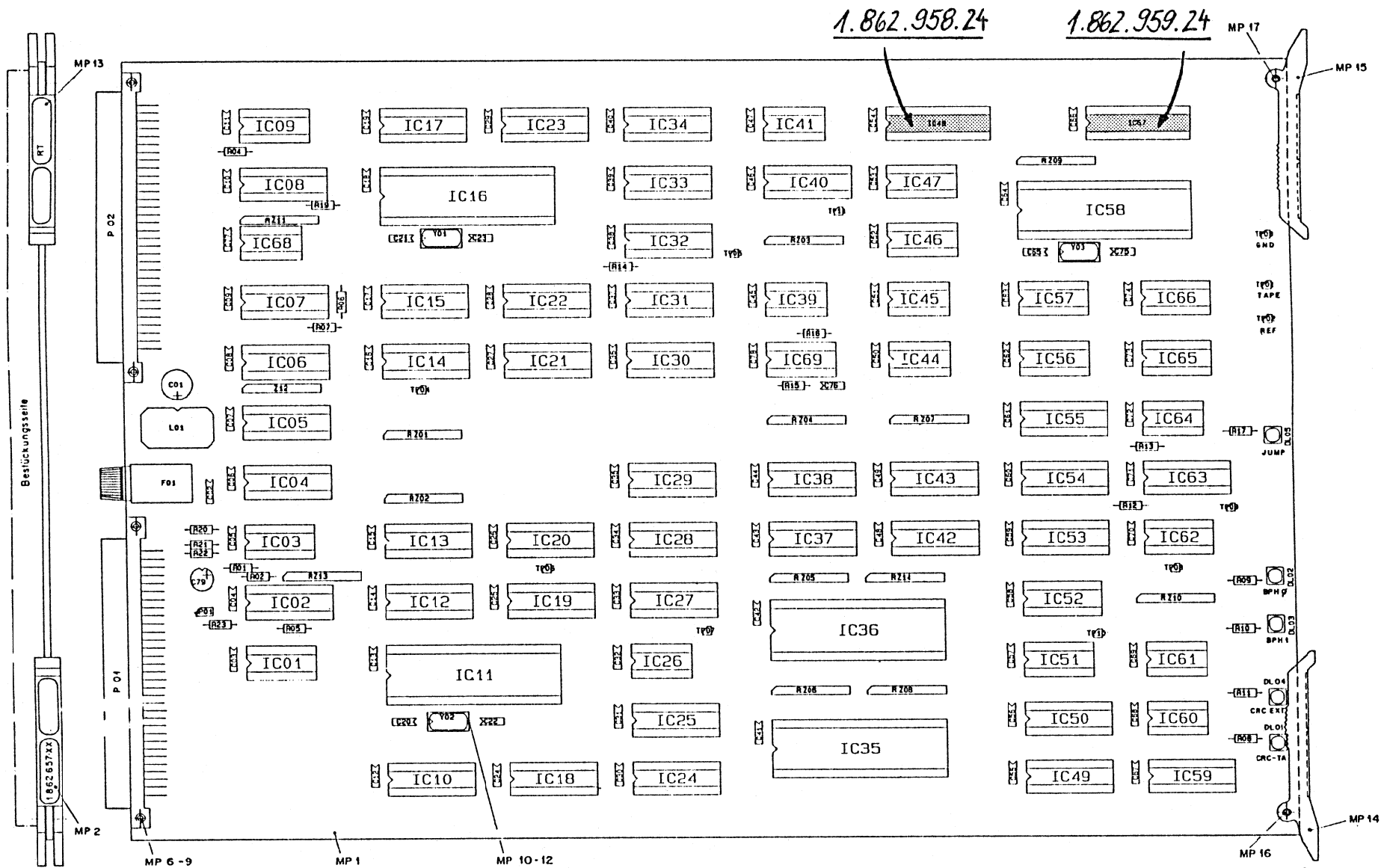

Version DIN Bez. Abmessung	Numm. Nr. DIN Bez. Abmessung	Umfang Quantität Beh.	
Zugfertiger (Mitarbeiter) PL, BV 640	Firmenabteilung Maffstab 4,3:1	Anzahl 28.8.89	28.8.89
Ersatz für	Ersetzt durch	Körper Nr.	
STUDER REGENSDORF ZÜRICH	REFERENCE TRACK ESE	1.862.657-24	

Modification Sound Memory 1.862.665.20

Problem:

New Master software V2.2 (28/91).

Remedy:

- Replace IC05 (old software number 1.862.892.20) by new software 1.862.892.21.
- Replace IC17 (old software number 1.862.891.20) by new software 1.862.891.21.
- Replace IC30 (old software number 1.862.890.20) by new software 1.862.890.21.

Change board index to new 1.862.665.21 .

Concerns machines delivered before July 1991.

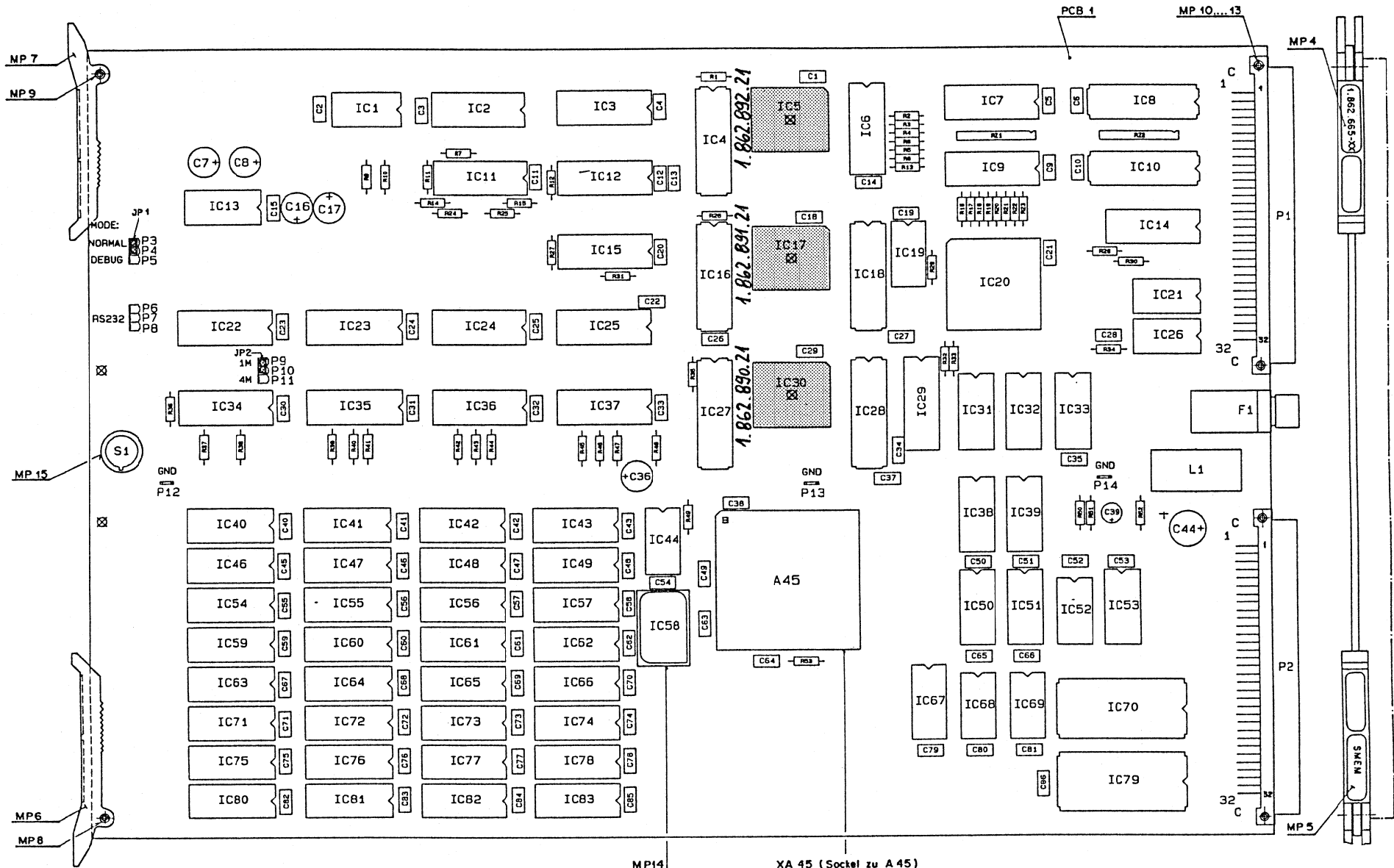

MP14

XA 45 (Sockel zu A 45)

Schilder MP1...MP3 aufgeklebt
nach Fabrikationsmuster.

IC Sockel nach PL besückt
z.B. XIC 5 = Sockel von IC 5

SOUND MEMORY 1.862.665.21

Modification MP Unit Tape Deck Control 1.862.781.21

Problem:

New Master software V2.2 (28/91).

Remedy:

- Replace IC16 and 18 (old software number 1.862.797.21) by new software 1.862.797.22.

Change board index to new 1.862.781.22 .

Concerns machines delivered before July 1991.

Bestückungsseite

MP-UNIT TD CONTROL MCH 1.862.781-XX

1,5 ÷ 2,5 mm Lötstellenhöhe

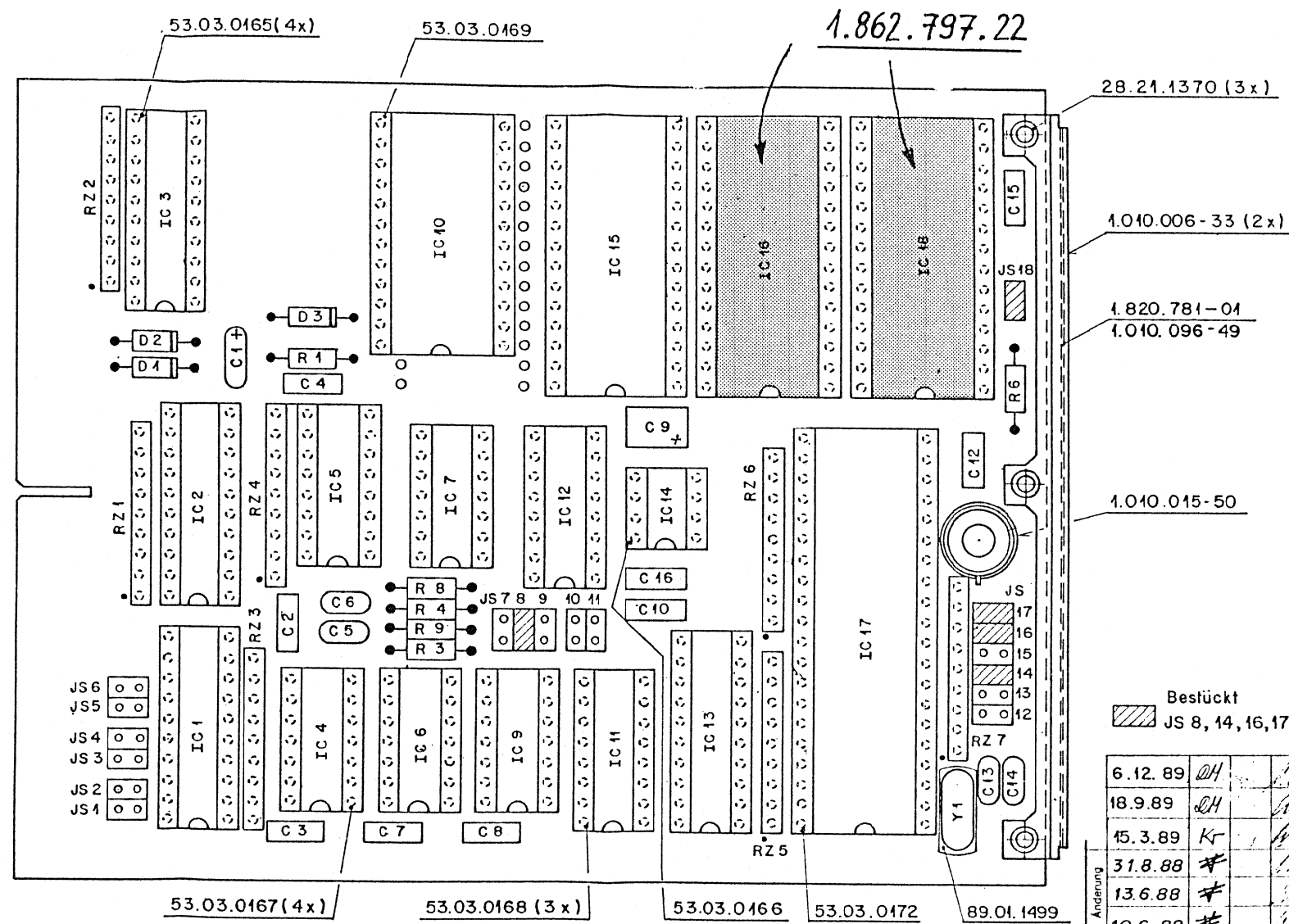

Bestückt
JS 8, 14, 16, 17, 18

6.12.89	DH			(25)
18.9.89	DH			(24)
15.3.89	Kr			(23)
31.8.88	#			(22)
13.6.88	#			(21)
10.6.88	#			(20)

Zugehörige Unterlagen: PL	Freimasstoleranz: +	Maßstab: 2:1	Ausgabe 711.86 RW		
Ersatz für:	Ersetzt durch:	Kopie für:			
STUDER REGENSDORF ZÜRICH	Benennung: MP-UNIT TD CONTROL MCH	ESE	Nummer: 1.862.781-22		

Modification Display Panel uP-Board 1.862.815.21

Problem:

New Master software V2.2 (28/91).

Remedy:

- Replace IC28 (old software number 1.862.825.21) by new software 1.862.825.22.
- Replace IC29 (old software number 1.862.826.21) by new software 1.862.826.22.

Change board index to new 1.862.815.22 .

Concerns machines delivered before July 1991.

1.862.826.22

1.862.825.22

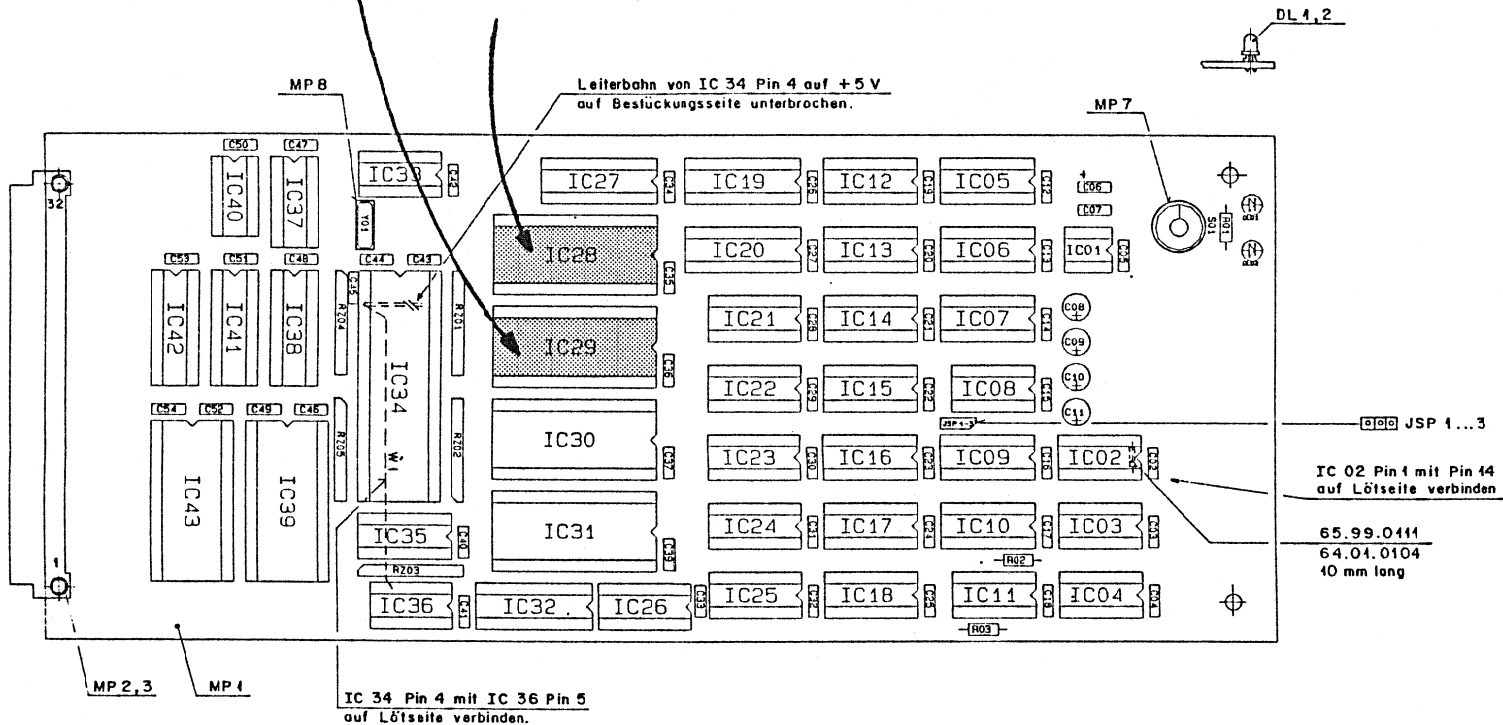

IC-Sockel nach PL bestückt
z. B. XIC 28 = Sockel von IC 28

Schilder MP 4, 5, 6
aufgeklebt nach Fabrikationsmuster.

Werkstoff:	Norm-Nr.:	Güte:	Anordnung		③
	DIN-Bez.:	Oberfläche:			②
	Abmessung:	Beh.:			①
Zugehörige Unterlagen:	Fremdatoleranz:	Maßstab:	15.6.90	15.6.90	④
PL	+	1,3:1	Datum	Gez. Gepr. Ges. Index	
Ersatz für:	Ersetzt durch:		Kopie für:		
STUDER REGENSDORF ZÜRICH	DP MP 6803+ SERBUS TRM / REC ESE		1.862.815-22		

Modification PAI Rembus uP6803 1.328.631.20

Problem:

New Master software V2.2 (28/91).

Remedy:

- Replace IC514 (old software number 1.328.896.20) by new software 1.328.896.21.

Change board index to new 1.328.631.21 .

Mark also index "21" on backside of case.

Concerns Parallel Audio Interfaces delivered before July 1991.

1.328.631.21

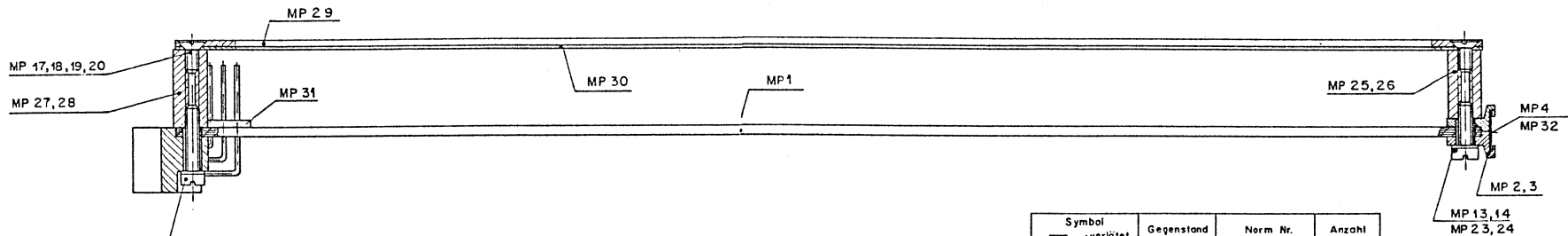
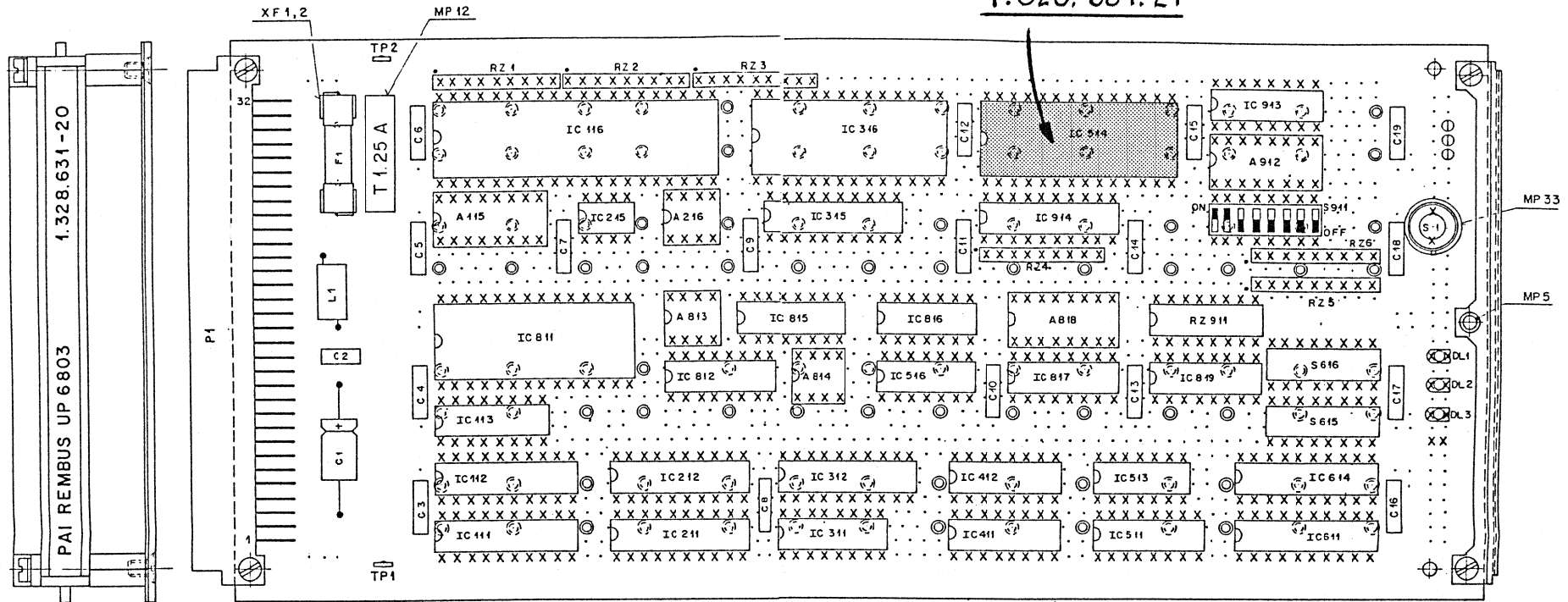

Symbol	verlötet	Gegenstand	Norm Nr.	Anzahl
⊕	⊕	Front Pin	1.010.027-54	3
X	⊕	Kontakt Pin	1.010.028-54	714
○	⊕	Dummy Pin	1.010.029-54	412

Norm-Nr.	Gute		Änderung
Werkstoff	Oberflächen		
DIN-Bez.	Beh.		
Abmessung	Fremsstoleranz:		Ausgabe
Zugehörige Unterlagen:	Maßstab:		
PL, BV670	2:1		18.4.90
Ersatz für	Ersetzt durch		Datum
STUDER REGENSDORF ZÜRICH		PAI REMBUS UP 6803 ESE	Gez. Gepr. Gez. Index
Bezeichnung		1.328.631-21	Gez. Gepr. Gez. Index
Nummer		1.328.631-21	

2. Modifications: Hardware

Modification concerns:

- 1.862.812.00 Display Panel Aux Key Detection

Modification set contains:

- 4 x Resistor 6.8 k Ω (57.11.3682)
- 4 x Resistor 10 k Ω (57.11.3103)
- 4 x Resistor 33 k Ω (57.11.3333)
- 4 x Zener diode 5.1V (50.04.1112)

Furthermore:

- 1.862.620.00 Power Supply

Due to some electrical improvements the power supplies will be exchanged to type .81. Please inform STI on the confirmation sheet if your machine is equipped with Version .00.

- Board Status

You will find attached in chapter 5 a status control sheet. Please check your machine for correspondence.

Please inform STI on the confirmation sheet about any differences.

Modification Display Panel Aux Key Detection 1.862.812.00Problem:

Synchronous power-down of all four power supplies not possible.

Cause:

Critical dimensioning under certain temperature conditions.

Remedy:Step A (all four DP Aux Key Detection Boards):

Replace R19 (47k Ohm, 57.11.3473) by 33k Ohm (57.11.3333).

Replace R20 (47k Ohm, 57.11.3473) by 10k Ohm (57.11.3103).

Replace R22 (4.2k Ohm, 57.11.3422) by 6.8k Ohm (57.11.3682).

Replace D06 (2.4 V, 50.04.1131) by 5.1 V (50.04.1112).

Step B (only SLAVE DP Aux Key Detection Boards):

Remove R23 (10k Ohm, 57.11.3103).

Step C

Please check for correct Jumper setting for MASTER / SLAVE operation as indicated on the boards (refer to board arrangement).

Change board index for SLAVE-Boards to new 1.862.812.81.

Change board number for MASTER-Board to new 1.862.814.00.

Concerns machines delivered before July 1991.

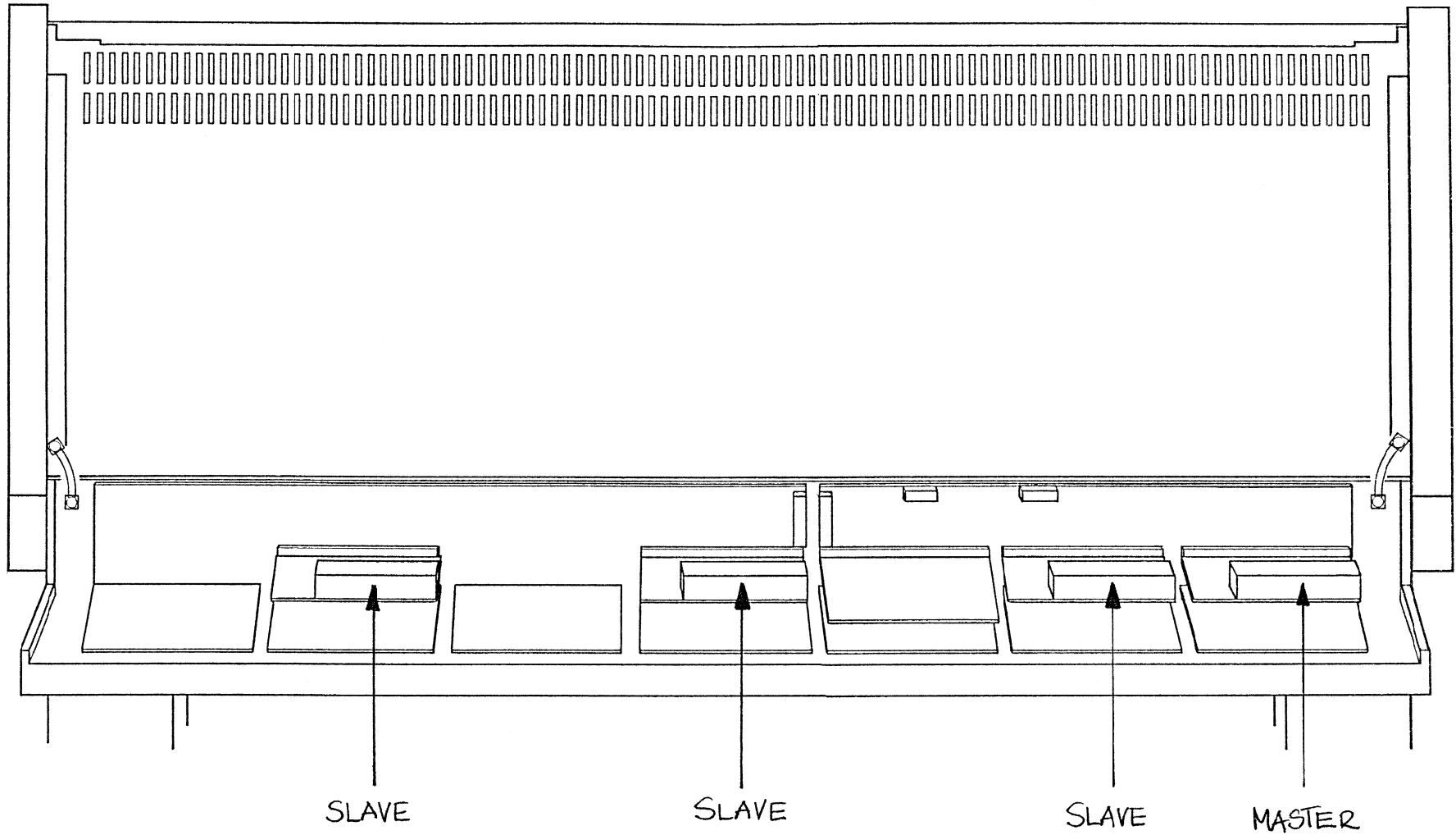

DISPLAY PANEL D820-48 (BOARD ARRANGEMENT)

- DP AUX KEY DETECTION BOARDS (SLAVE) 1.862.812.81
- DP AUX KEY DETECTION BOARD (MASTER) 1.862.814.00

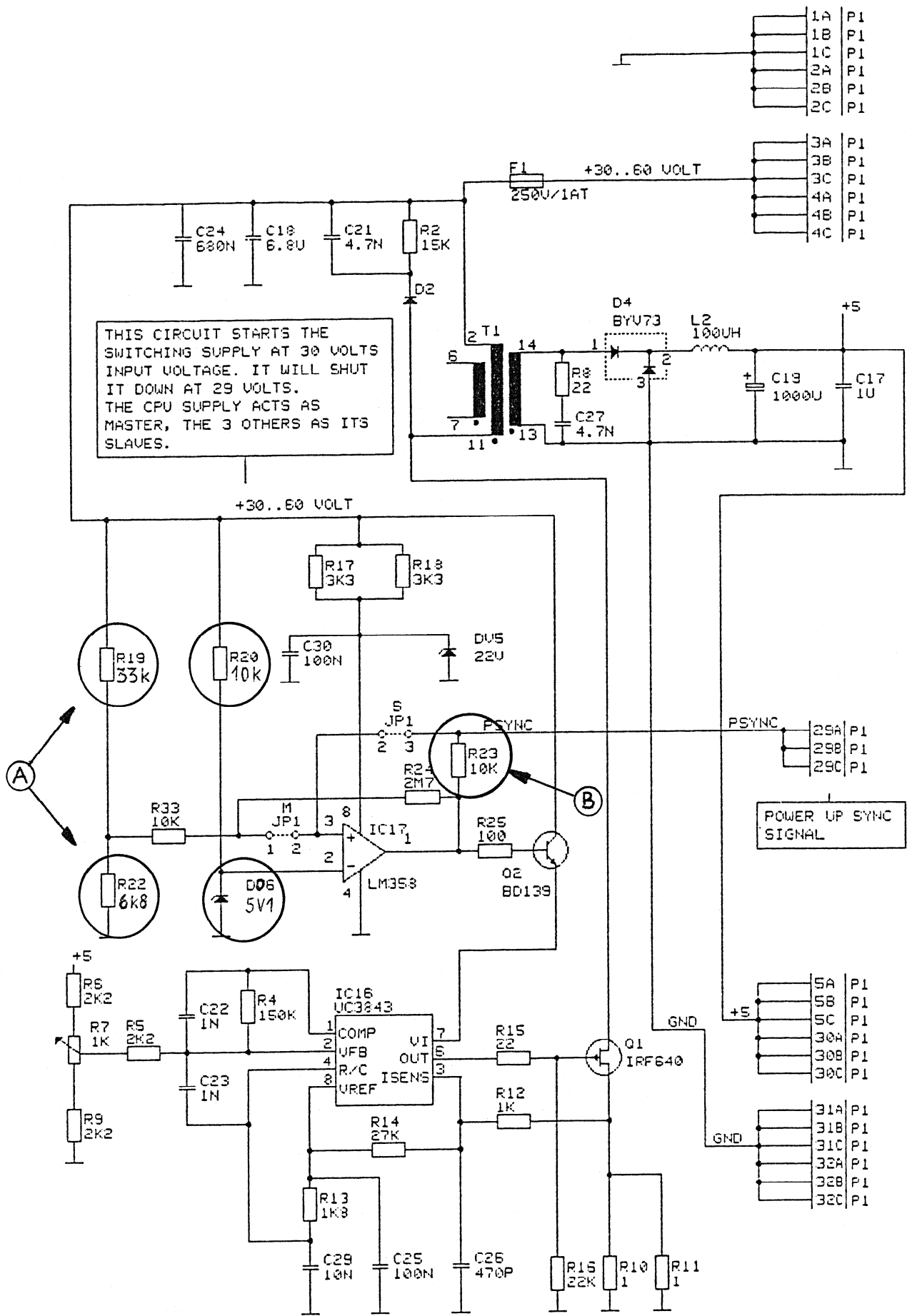

THIS CIRCUIT STARTS THE SWITCHING SUPPLY AT 30 VOLTS INPUT VOLTAGE. IT WILL SHUT IT DOWN AT 29 VOLTS. THE CPU SUPPLY ACTS AS MASTER, THE 3 OTHERS AS ITS SLAVES.

A

B

C

JUMPER JP1 INSERT M FOR SLAVE OPERATION INSERT S FOR MASTER OPERATION

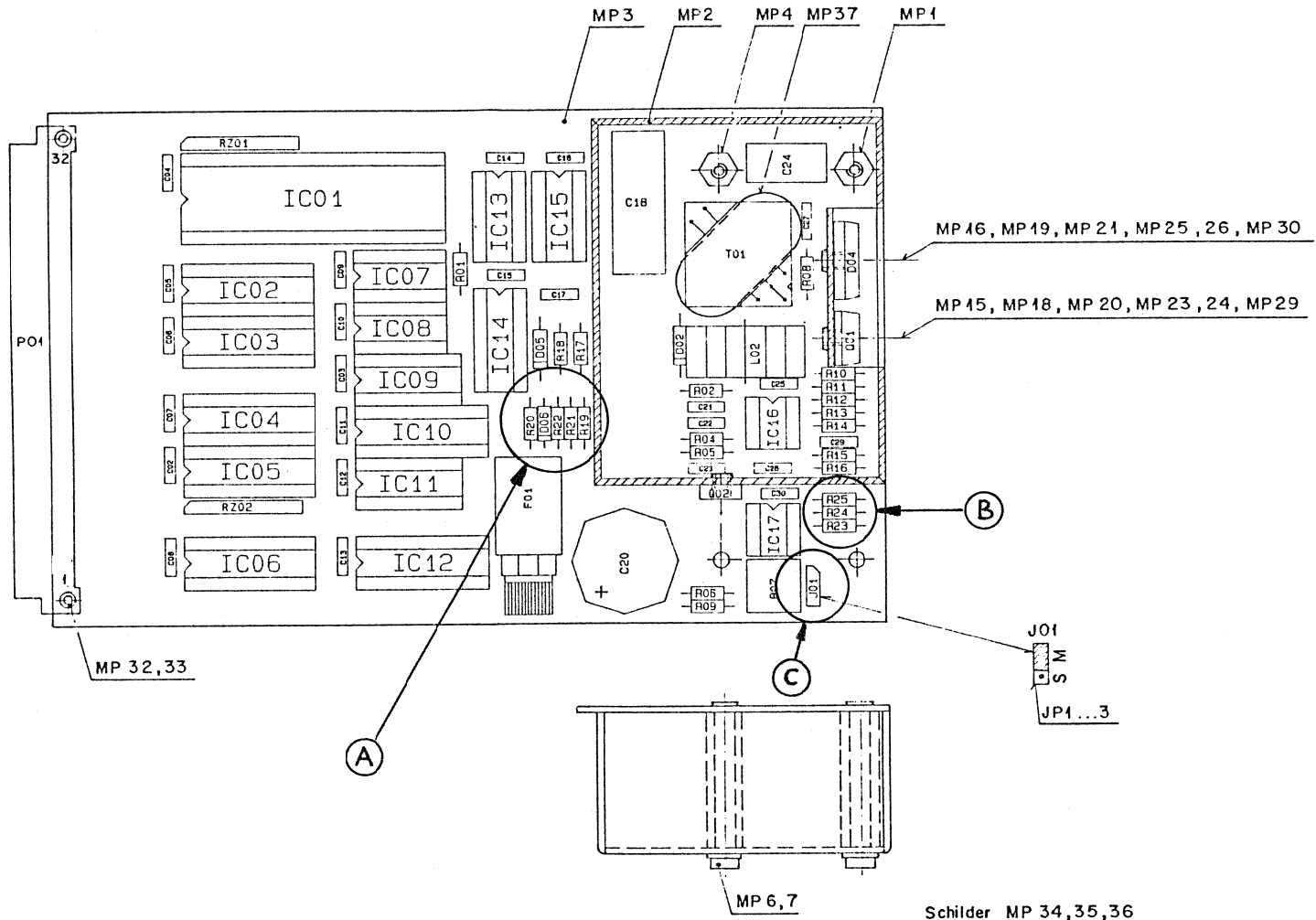

Schilder MP 34,35,36
aufgeklebt nach Fabrikationsmuster.

Werkstoff	Norm-Nr.:	Oberfläche	Gute:	Änderung	③
	DIN-Bez.:		Beh.:		②
	Abmessung:				①
Zugehörige Unterlagen:		Freimasstoleranz:	Maßstab:	Ausgabe	
PL, BV 6 40, BV 632		±		14.6.90 <i>1.862.812-81</i> ④	
Ersatz für:		Ersetzt durch:		Kopie für:	
STUDER REGENSDORF ZÜRICH		Benennung: DP AUX KEY DETECTION ESE		Nummer: 1.862.812-81	

3. Improvements in S/W 2.2

3.1 <GROUP> and <ALL READY>

Key sequence <ALL READY> and then <GROUP 1...4> is now also possible.

3.2 Internal Synchronizer

Lock-Play performance has been improved.

3.3 REHEARSE

<REHEARSE> is now also possible to select in all machine states except during RECORD or when the machine is in <NEW REC> mode.

<REHEARSE> is automatically switched "off" when <NEW REC> is selected.

<REHEARSE> is automatically switched to "on" when <AUTOLOAD> is selected. <REHEARSE> returns to its previous state when leaving <AUTOLOAD>.

3.4 AUTOLOAD WITH REHEARSE

AUTOLOAD now switches <READY>-selected channels correctly to the corresponding INPUT/REPRO-state.

3.5 TC Locator on 24 h-boundary

Locates around the 24 h boundary are now performed correctly.

3.6 Tape Drift after power on

Slow drifting of tape due to incorrect reel measurements is now removed.

3.7 Sound Memory Punch-in delay

Punch-in has been improved and is now performed without gap.

3.8 Sound Memory Time Display

During playback from the SMEM the display shows the current play position. BEGIN and END points are also shown with their absolute values.

Display time resolution in <PLAYBACK> is 100 ms.

3.9 Sound Memory Trimming

Minimum memory length to be trimmed is now limited to twice the internal crossfade-time of the sound memory (approximately 17 ms).

During trimming the sound memory contents will be output.

3.10 Sound Memory Auto Loop Play-Mode

Begin and end points which are set on the fly now lead to a restart with the new set values in the next loop (same as in Break Play-Mode).

3.11 Track Slipping with Delay "0"

Delay "0" is now exactly compensated for sample exact copying.

3.12 Input/Repro status after power-up

Implementation is now the same as in the A820-series.

3.13 TC-Generator 29.97 Fr/s locked to Video Reference 29.97 Fr/s

"Drop-Frame" synchronization of the TC Generator has been improved.

4. Software Compatibility List

S/W Version 2.2, Release 28/91

<u>Software</u>	<u>IC</u>	<u>Release</u>	<u>IC-Type</u>	<u>Check</u>	<u>Identification</u>	<u>Hardware</u>
1.328.894.21	28	03/91	27128	1010	625 RDP PART ONE	1.328.625.21
1.328.895.21	29	03/91	27128	94BF	625 RDP PART TWO	1.328.625.21
1.328.896.21	514	28/91	27256		631 PAI MAIN PROGR.	1.328.631.21
1.328.898.21	04	03/91	27256	FE96	612 AL MAIN PROGRAM	1.328.612.22
1.328.899.21	05	03/91	27256	3A03	602 CR MAIN PROGRAM	1.328.602.22
1.862.796.21	17	03/91	27128	D52E	25/90 CAPST. PCM MCH	1.862.764.21
1.862.797.22	16	28/91	27128		52/89 TD PCM MCH	1.862.781.22
1.862.797.22	18	28/91	27128		52/89 TD PCM MCH	1.862.781.22
1.862.825.22	28	28/91	27128		815 DP PART ONE	1.862.815.22
1.862.826.22	29	28/91	27128		815 DP PART TWO	1.862.815.22
1.862.890.21	30	28/91	28HC64		665 56000 PROGRAM H	1.862.665.21
1.862.891.21	17	28/91	28HC64		665 56000 PROGRAM M	1.862.665.21
1.862.892.21	05	28/91	28HC64		665 56000 PROGRAM L	1.862.665.21
1.862.913.21		19/90	28HC64		652 MAPRO TMS PROG H	1.862.652.21
1.862.914.21		19/90	28HC64		652 MAPRO TMS PROG L	1.862.652.21
1.862.924.20	01	29/90	27256	612B	655 CPU BOOT H	1.862.686.21
1.862.925.20	02	29/90	27256	5623	655 CPU BOOT L	1.862.686.21
1.862.926.22	03	28/91	27011		655 CPU MAIN PR.SET	1.862.686.22
1.862.926.22	04	28/91	27011		655 CPU MAIN PR.SET	1.862.686.22
1.862.926.22	05	28/91	27011		655 CPU MAIN PR.SET	1.862.686.22
1.862.926.22	06	28/91	27011		655 CPU MAIN PR.SET	1.862.686.22
1.862.937.21	35	03/91	27256	IBEA	656 PIF MAIN PR.TDC	1.862.656.22
1.862.938.22	43	28/91	27256		656 PIF MAIN PR.SBC	1.862.656.22
1.862.939.20	61	29/90	27256	4BA7	656 PIF MAIN PR.SEC	1.862.656.22
1.862.940.21	68	03/91	27256	DDB9	656 PIF MAIN PR.RBC	1.862.656.22
1.862.956.20	10	32/89	28L22		657 RT TMS PR. PLL H	1.862.657.24
1.862.957.20	18	32/89	28L22		657 RT TMS PR. PLL L	1.862.657.24
1.862.958.24	48	28/91	7C263		657 RT TMS MAIN PR H	1.862.657.24
1.862.959.24	67	28/91	7C263		657 RT TMS MAIN PR L	1.862.657.24
1.862.967.21	40	03/91	27128	6CDC	659 SSTC SIGNAL UP	1.862.659.22
1.862.968.20	50	29/90	27128	CC89	659 SSTC CAPSTAN UP	1.862.659.22
1.862.980.21	31	10/90	7C263		685 TCGEN TMS PROG H	1.862.685.21
1.862.981.21	32	10/90	7C263		685 TCGEN TMS PROG L	1.862.685.21

D820-48

STATUS CONTROL SHEET A-28/91

Due to technical progress and improvements the following boards have been modified since the introduction of the machine. The actual index state is listed below. Please check for correspondence and answer on the confirmation sheet.

A 1:	Power Supply	1.862.620.81	
A 2:	D/A Converter	1.862.651.21	
A 3:	MAPRO	1.862.652.21	
A 4:	CPU FORCE	1.862.655.22	
A 5:	Periphery Interface	1.862.656.22	
A 6:	Reference Track	1.862.657.24	
A 7:	Synchronizer	1.862.659.22	
A 8:	Time Code Backbag	1.862.685.21	
A 9:	Clock Board	1.862.660.22	
A 10:	AES Interface	1.862.664.22	
A 11:	Sound Memory	1.862.665.21	
A 12:	DP Key Detection (Slave)	1.862.812.81	
A 13:	DP Key Detection (Master)	1.862.814.00	
A 14:	DP Microprozessor	1.862.815.22	
A 15:	Read Unit Cue Tracks	1.862.723.81	(.00 also o.k.)
A 16:	Tape Deck Serial Interface	1.820.763.83	
A 17:	Capstan Control Unit	1.862.764.21	
A 18:	MP-Unit TD Control PCM	1.862.781.22	
A 19:	Switching Stabilizer $\pm 15V$	1.820.873.82	
A 20:	Parallel Remote Interface	1.820.738.85	
A 21:	Tape Deck Display Driver	1.820.768.84	
A 22:	Motor Tacho	1.820.771.83	(.81 also o.k)
A 23:	Capstan Motor Drive Amplifier	1.820.774.25	

6. Mechanical Modifications and Improvements

The following mechanical and "embellishal" improvements are available:

6.1 Coloured Key Caps

A set of coloured key caps for

- Display
- Autolocator
- Channel Remote

is available on request. This improves the legibility and survey of the control elements.

6.2 Head Block Cover with engraved STUDER signature

Newer machines (1020 and up) are delivered with a head block cover with engraved STUDER signature.

This is available on request as a spare part (order no. 1.862.116.03).

6.3 3 Stickers for Rack Doors

For a better serviceability letterings for the rack doors are provided to indicate board locations and assigned control elements and LEDs on the boards.

The stickers are available as spare parts.

- Lettering for upper PCM rack (order no. 1.862.640.51)
- Lettering for lower PCM rack (order no. 1.862.640.52)
- Lettering for tape deck section (order no. 1.862.554.04)

6.4 New Colour of Panel Background

20 machines in between serial numbers 1011 to 1035 are delivered with a light grey backgrounded display.

In situations of bad light conditions is the legibility limited. A replacement is available for

- Display Panel (order no. 1.862.800.06)
- Autoloactor (order no. 1.328.610.01)
- Channel Remote (order no. 1.328.600.01)

The control panel for the Sound Memory is only, delivered with the new dark grey background. If the colour doesn't match to that of the Autolocator and Channel Remote, the replacements will be delivered on request free of charge.

6.5 New Move Pulse Roller (1.820.410.11)

Slipping of tape on the move pulse roller was detected under several conditions (tape manufacturer, used/unused tape ..). To prevent slipping and reach a more exact move pulse counting an improved move pulse roller is provided.

The new roller will be reworked out of the old version. New move pulse rollers are marked with an engraved flute on the upper edge.

The new roller was shipped with the software update V 2.1.

<p>SI 154/91</p> <p>CONFIRMATION OF PERFORMED UPDATE</p> <p>D820-48 Serial No.:</p>	
<p>Representative organization: _____</p>	
<p>Date: _____</p>	<p>Issued by: _____</p>

Please complete the confirmation sheet when the update has been performed. Return a copy to STI (Product Support D820-MCH). Thank you for cooperation.

1. The D820-48 is updated to S/W 2.2 (28/91)
SI 154/91 has been performed.
 - YES
 - NO, NOT POSSIBLE BECAUSE:
 - _____
 - _____
 - _____

2. The boards' index states correspond to the status control sheet A-28/91.
 - YES
 - NO.
 - FOLLOWING BOARDS NEED AN UPDATE
 - _____
 - _____
 - _____

3. Missing mechanical modifications:
 - _____
 - _____

4. Remarks: